

How to Give a Good Research Talk*

Stephen D. Scott

November 21, 2008

*Adapted from Sally Goldman's slides.

Why Are We Here?

- For your work to have significant impact, it is essential that you can convey results to your community
- Your technical reputation depends on colleagues' reaction to your talk
- When on the job market this skill will be crucial in getting a research position in academics or industry
- Giving a good talk is a skill you can learn
- I will give you guidance and tips on giving a good talk

Goals of a Talk

- Meta-Goal:
 - keep audience's interest (and attention)
 - convey technical material
 - communicate a key idea of work
 - provide intuition
 - convince audience to read your paper
- Non-Goals:
 - show people how smart you are
 - expect audience to understand most key details of your work

Outline

- Goals of a Talk
- Planning Stages
- Structuring Your Talk
- Slide Preparation
 - The Do's
 - The Don'ts
- At the Talk
 - The Do's
 - The Don'ts
- Concluding Remarks

Planning Stages

- Know your audience:
 - What is their background?
 - * general CS (or EE)
 - * somewhat specialized audience
 - * highly specialized audience
- If someone has spoken before you:
 - Look at paper/abstract of relevant talks that preceeded yours
 - Prepare to use context provided

Scheduling (if you can)

- If possible schedule your talk at 10:00
 - most people are awake
 - few have gone back to sleep
- Bad times to schedule talk:
 - right before lunch since the audience is thinking about food
 - after lunch since the audience is more likely to be sleepy
 - late afternoon since people will be running out of steam
- Best to have room that will be comfortably crowded

Structuring Your Talk

- Use a top-down approach:
 1. Introduction: define problem, present a “carrot”, put in context, and give outline
 2. Body: high-level summary of key results
 3. Technicalities: more depth into a key result
 4. Conclusion: review key results, wrap up, give future work

The Introduction

- Define the Problem
 - *minimize use of terminology*
 - *use pictures/examples/props if possible*
- Motivate the audience (give a “carrot”)
 - why is problem important?
 - how does it fit into larger picture?
 - what are applications?
- Discuss related work
 - table useful (mention authors and dates)
- Succinctly state contributions of your work
- Provide a road-map (outline)

Concept Class of One-Dimensional Patterns

- The instance space \mathcal{X}_n consists of all configurations of n points on the real line
- A concept is set of all configs. from \mathcal{X}_n within unit distance under **Hausdorff metric** of some “ideal” configuration of k points, where Hausdorff distance between configs. P and Q is

$$H(P, Q) = \max \left\{ \max_{p \in P} \left\{ \min_{q \in Q} \{d(p, q)\} \right\}, \max_{q \in Q} \left\{ \min_{p \in P} \{d(p, q)\} \right\} \right\}$$

and $d(p, q)$ is distance between p and q

- If P is any configuration of points on \mathbb{R} , then concept corresponding to P is

$$C_P = \{X \in \mathcal{X}_n : H(P, X) \leq 1\}$$

- X is a **positive example** of C_P if $X \in C_P$ and is a **negative example** otherwise

- Concept class of one-dimensional patterns is

$$\mathcal{C}_{k,n} = \{C_P : P \text{ is a configuration of } \leq k \text{ points from } \mathbb{R}\}$$

Concept Class of One-Dimensional Patterns

- Each **concept** c is a set of fixed-width intervals on real line
- Each **example** X is a set of points on real line
- Example X is **positive** if and only if:
 1. each of X 's points lies in an interval from c
 2. each interval of c contains a point from X

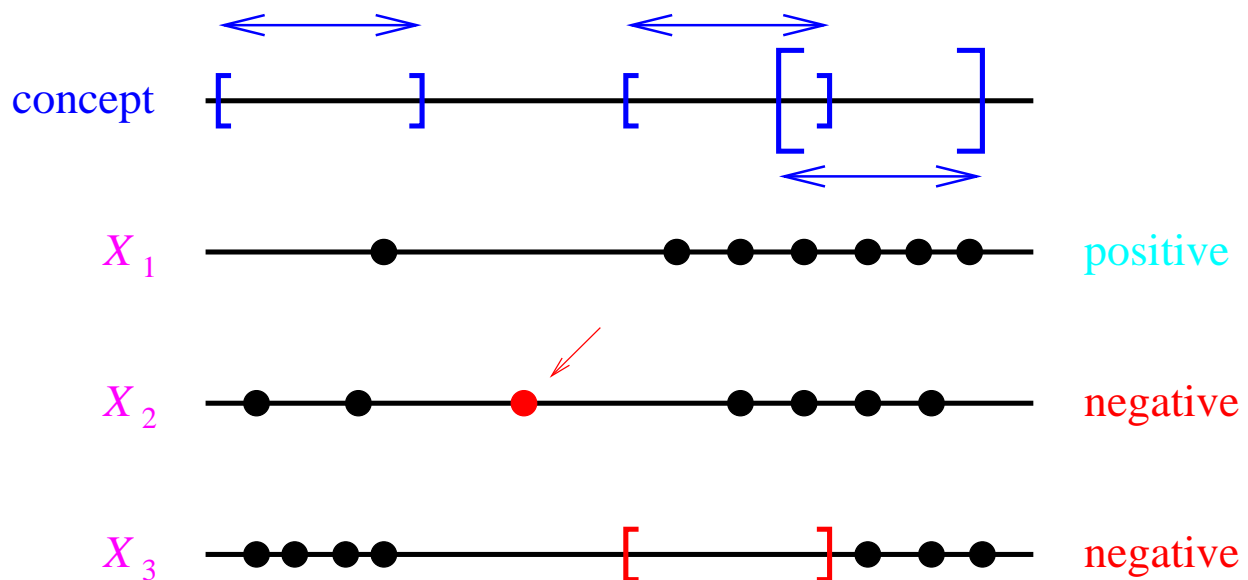

The Body

- Abstract the key results
 - focus on a central, exciting concept
- Explain significance of your work
- Sketch methodology of key ideas
 - keep it high-level, emphasizing structure
 - use pictures/diagrams if possible
 - provide intuition (helpful when someone later reads your paper)
 - gloss over technical details

The Technicalities

- Take key result (or part of it) and go into some depth
- Guide audience through difficult ideas
 - give overview
 - state result
 - show an example
 - review
- It is this portion of your talk that typically grows when you give a 50 minute talk

The Conclusion

- Provide a coherent synopsis
- Review key contributions and why they are important
- Discuss open problems/future work
- Indicate your talk is over. (For example, “Thank you. Are there any questions?”)
- Be ready to answer questions
 - If there are points you glossed over that you expect the audience may be interested in, you may want to prepare some slides (just in case)

Slide Preparation—Do's

- Decide what you want to say and say less!
- Allow an average of 1.5–2 minutes for each slides
- Use Repetition
 - “Tell them what you’re going to tell them. Tell them. Then tell them what you told them.”
 - Realize that 20% of your audience at any given time is thinking about something else
- Use pictures/diagrams whenever you can

Slide Prep—Do's (cont'd)

- Use a large font (at least 20 pt)
- Make neat/orderly slides (computer-generated preferable)
- Use overlays or other “scaffolding”
- Use color/animation (in a meaningful way)
- You need not use full sentences
- Number your slides
- Write reminders, key phrases, etc. on paper

Slide Prep—Do's (cont'd)

- Check your spelling
- If you use a slide more than once, duplicate it
- PRACTICE!
 - give a practice for your colleagues, advisor, friends, pets, etc.
 - be ready to redo all your slides
 - practice again
 - be sure that all your material projects on the screen
 - make sure it does not take too much time
(Beware PowerPoint's timer!)

Slide Preparation—Don'ts

- Overload slides
- Intend to use too many slides
- Put some detail on the slide that you do not want to talk about
- Get bogged down in details
- Try to give a core dump

Slide Preparation—Don'ts (cont'd)

- Show complex equations
- Show complex code (even pseudocode)
- Have a slide that introduces a point that you are unsure of (unless you want to give the audience a chance to attack you)
- Present last-minute results (they are probably wrong)
- Have slides that you are not using mixed in with the rest
- Write messy, write (or use a font that is) too small, misspell words

At the Talk—Do's

- If you expect the audience to take notes, provide copies of your slides
 - Rarely the case at a conference or colloquium/job talk
- Dress appropriately—this shows respect for your audience
- Have eccentricity (but not too extreme)
 - make it fun/easy for people to remember you
 - extreme eccentricity is bad for younger people

At the Talk—Do's (cont'd)

- Be EXCITED about your work!
- Remind; don't assume
 - If you assume a standard result, provide the audience with a brief reminder
- **Talk with Sufficient Volume**
- Make eye contact and “read” the audience
 - Change victims
- Be with the audience
 - Walk toward and away from the people as well as left and right to break down implicit barrier

At the Talk—Do's (cont'd)

- Point to the screen, not slide/computer monitor
 - Use a pointer, not hand/pen
- Bring props
- Ask real and rhetorical questions to keep audience engaged
- Deflect obstructionists:
 - tell them you'd like to talk to them after the talk (about the interesting point made) because the point is a detail, tangential, has a long answer, you need to think about it, etc.
- End on time!

At the Talk—Don'ts

- Talk too softly, mumble, or speak in a monotone voice, use “um”, “ah”, ...
- Read your slides
- Focus attention on the screen—you'll end up talking to the screen vs. the audience
- Stand so that you block the projection
- Mention a detail/point you don't want to talk about
- Darken the room (unless necessary to see) since it entices audience to sleep
- Babble on when you have nothing to say
- Run over time

Concluding Remarks

- Follow the guidelines provided here
- Take every opportunity you can to give talks (and thus get practice and feedback)
- Remember that the guidelines for structuring your talk must be adapted to each specific talk
- Preparing a good talk takes time; do not expect to throw it together at the last minute
- Practice for colleagues, etc. to get feedback
- AND: you will give better talks and reap the rewards that follow